



FLUX-JET

1,1 kW (FLUX 80) - 1,5 kW (50 Hz)
1,3 kW (FLUX 80) - 1,5 - 1,75 kW (60 Hz)

Del presente modello sono disponibili anche le seguenti versioni speciali:
This model is also available with the following specifications:

- ANODIZZATO / ANODIZED TREATMENT
- TEFLONATO / TEFLON TREATMENT
- ANTIDEFAGRANTE / FLAME PROOF / EXPLOSION PROOF
- a richiesta **TENSIONI SPECIALI** / SPECIAL VOLTAGES on request

MOTORI COSTRUITI SECONDO LE NORME CEI 2-3 (1988) ISOL. CL F PROT. IP 54
MOTORS CONSTRUCTION CONFORM WITH CEI 2-3 (1988) NORMS. ISOL. CL F PROT. IP 54

ARTICOLO ITEM CODE	kW	V	Hz	assorb. AMP. absorbed. AMPS.	giri/min r.p.m.	LIMITE SERVIZIO MAX CONT. DUTY S1 mmH ₂ O	μF/V	dB (A)*	PESO Kg WEIGHT Kg
-----------------------	----	---	----	---------------------------------	--------------------	--	------	---------	----------------------

MONOFASE	048137	1,1	230	50	7,6	2830	-1500 +1500	40/450	71	21
	048139	1,5	230	50	9,5	2820	-1900 +1900	40/450	71	21
	048116	1,5	220	60	10,8	3475	-1800 +1800	40/450	71	21
TRIFASE	049100	1,1	230 Δ 400 Y	50 50	5 2,9	2800	-1500 +1500		68	19
		1,3	265 Δ 460 Y	60 60	5 2,9	3450	-1400 +1300		71	19
	048111	1,5	230 Δ 400 Y	50 50	6,4 3,7	2800	-1900 +1900		68	21
		1,75	265 Δ 460 Y	60 60	6,4 3,7	3450	-1900 +1800		71	21

* Livello di pressione sonora rilevato secondo le Norme ISO 3746 - 1979 (E). Parametri: r=1 - Rumore di fondo ≤ 51 dB (A) - Strumento: Brüel & Kjær type 2232.
* Sound pressure level tested according to ISO regulation 3746 - 1979 (E). Parameters: r=1 - Background noise ≤ 51 dB (A) - Instrument: Brüel & Kjær type 2232.

DIMENSIONI DIMENSIONS

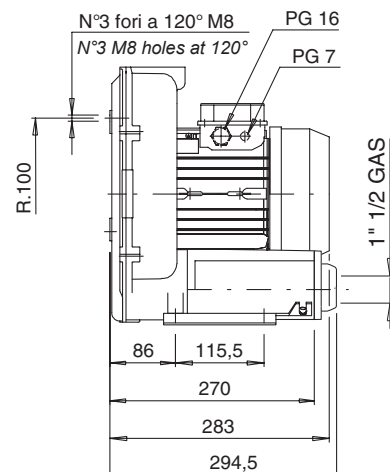
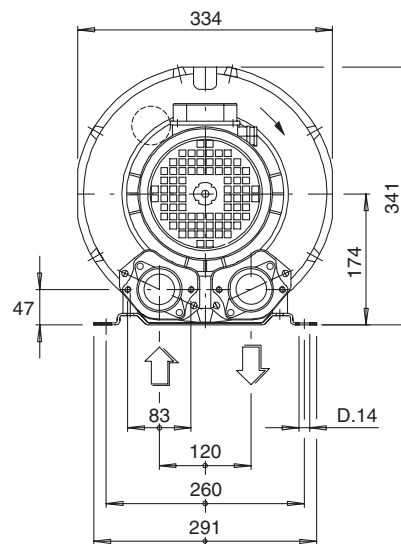

Le dimensioni di ingombro sono espresse in millimetri
All dimensions are in mm.

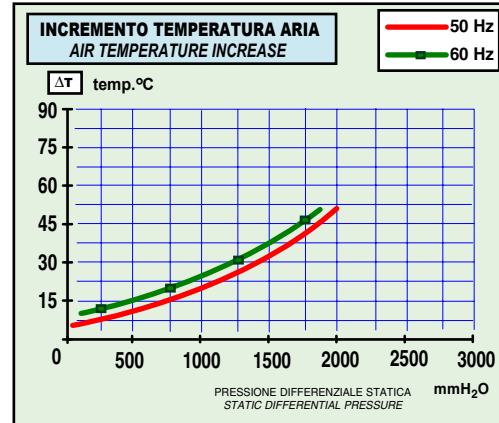
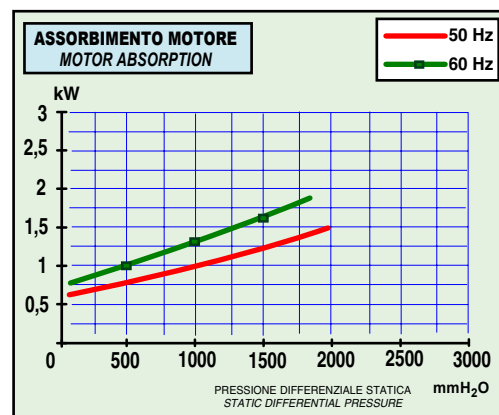
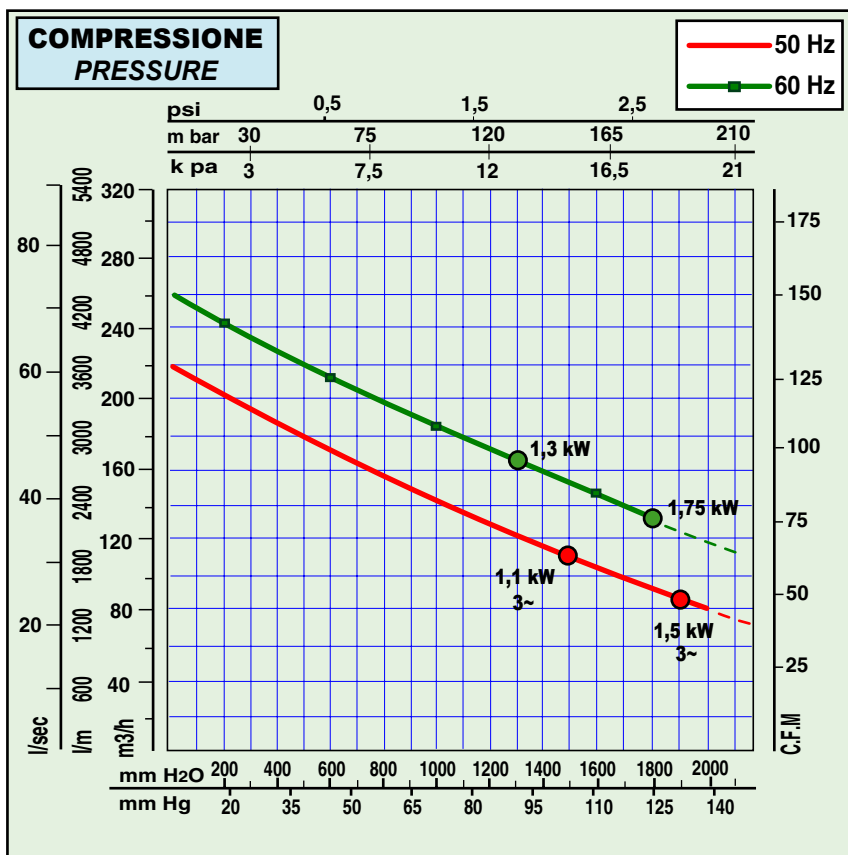
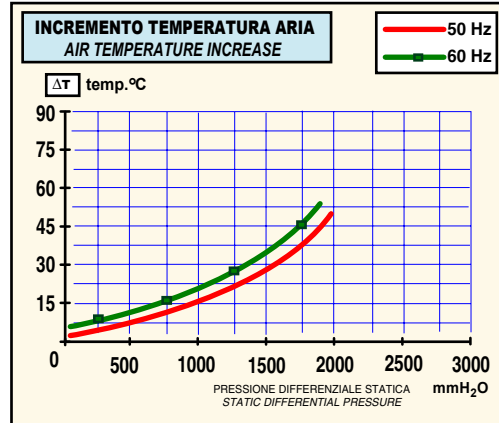
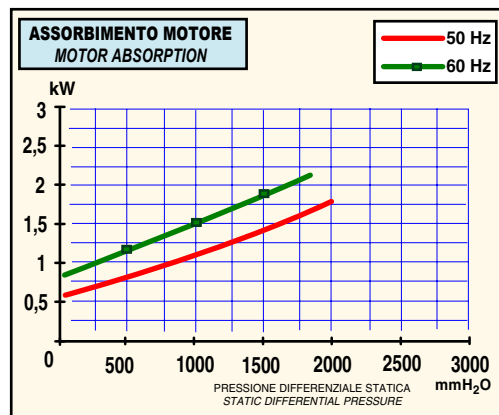
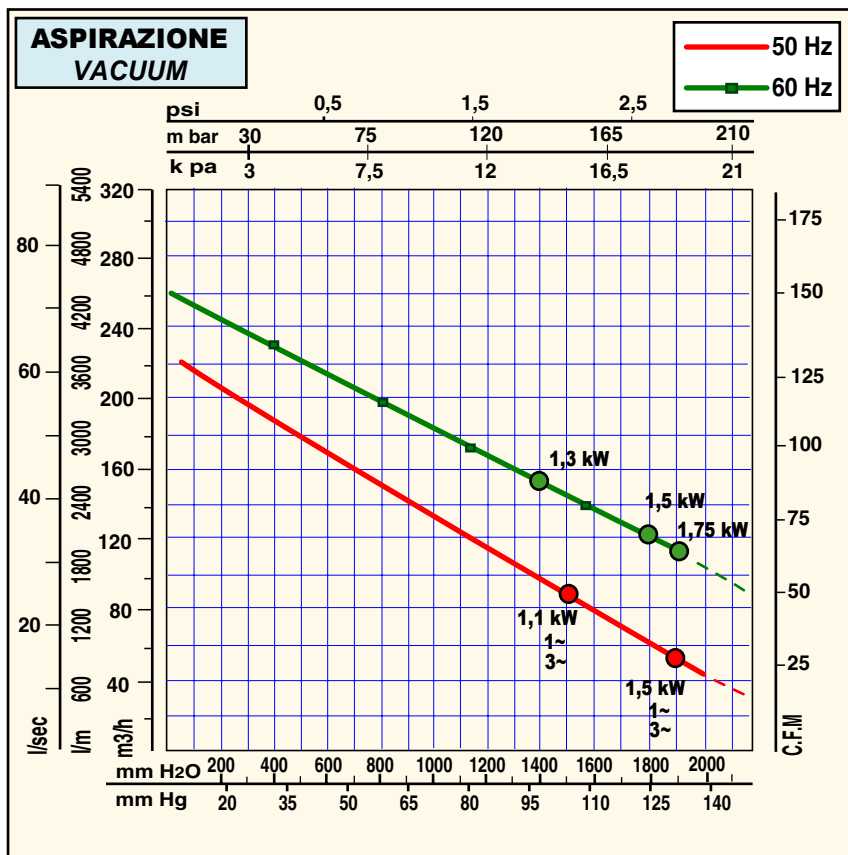

Tutti i dati della presente scheda tecnica si intendono indicativi e potranno essere modificati dalla casa in qualsiasi momento senza nessun preavviso.
La curva di aspirazione è riferita ad aria alla temperatura media di 20 °C e 1013 mbar sul raccordo di mandata.
La curva di compressione è riferita ad aria alla temperatura media di 20 °C e 1013 mbar sul raccordo di aspirazione.

All data is intended as an indication and may be modified without prior notice.

The vacuum curve is valid for pumping air, with a temperature of 20°C at the inlet flange and with a pressure of 1013 mbar at the discharge port.

The pressure curve is valid for pumping air, with an average temperature of 20°C and 1013 mbar at the inlet flange.

Valore max di pressione per servizio continuativo
Max value for continuous duty

1~ = MonoFase / Single Phase
3~ = TriFase / Three Phase